



NCTC – North Central

cloudUC Training  
Guide – Polycom  
Prepared for  
CUSTOMER NAME

Rev 2

1/27/2020

## Table of Contents

<b>NCTC – North Central</b> .....	0
Extension List .....	3
DIDs (Direct Inward Dial #s) .....	3
Virtual Numbers .....	3
Virtual Extensions .....	3
Personal Hosted Fax Numbers .....	3
Shared Hosted Fax Numbers .....	3
Standalone Mailboxes .....	3
Additional Training Information .....	3
NCTC cloudUC Customer Admin Portal (CAP) .....	4
Related NCTC cloudUC Applications .....	5
nCommand .....	5
Broadsoft Recorder .....	5
Polycom Devices .....	6
Using Your Polycom Device .....	19
To Place a Call .....	19
To Answer a Call .....	19
Mute .....	20
Volume .....	20
To Place a Call on Hold .....	20
To Transfer A Call To Another Extension .....	20
To Perform a Consult Transfer: .....	20
To Perform a Blind Transfer: .....	20
To Transfer A Call to Another Extension Using BLF Key .....	20
To Transfer A Call Directly to A Mailbox .....	20
To Park a Call .....	20
To Retrieve a Parked Call .....	21
To Setup your Voice Mail .....	21
To Record Voice Mail Greetings .....	21
To Listen To Voice Mail Messages .....	21
To Transfer A Message to Another User .....	21
Call Forwarding .....	21

Call Forwarding via Telephone..... 22

Call Forwarding via Feature Code ..... 23

Call Forwarding via Customer Admin Portal ..... 23

Do Not Disturb ..... 24

Call History ..... 24

Redial ..... 24

Conference Calling ..... 25

Feature Codes ..... 26

## Extension List

X1000 User Name

X1001 User Name

X1002 User Name

X1003 User Name

X1004 User Name

## DIDs (Direct Inward Dial #s)

X1000 User Name NPA-NXX-XXXX

X1001 User Name NPA-NXX-XXXX

X1002 User Name NPA-NXX-XXXX

X1003 User Name NPA-NXX-XXXX

X1004 User Name NPA-NXX-XXXX

## Virtual Numbers

Main Number	NPA-NXX-XXXX	Ring In Destination
-------------	--------------	---------------------

## Virtual Extensions

Not Applicable

## Personal Hosted Fax Numbers

Not applicable

## Shared Hosted Fax Numbers

Not Applicable

## Standalone Mailboxes

Not Applicable

## Additional Training Information

To access additional product information including training videos, please visit

<http://www.nctc.com/nctc-clouduc>

## NCTC cloudUC Customer Admin Portal (CAP)

The NCTC cloudUC Customer Administration Portal (CAP) provides complete access to all functions of your cloudUC service. Users are designated as End Users or Administrators when they are created and can be changed at any time. End Users can view/modify settings related to their account only where Administrators can modify all system and user settings.

To access the NCTC cloudUC CAP all that is required is a browser and an Internet connection.

<https://clouduc.nctc.com>

In order to log in, a valid username and password is required. During account setup, a username and password was created. Please consult with your system administrator for further information.

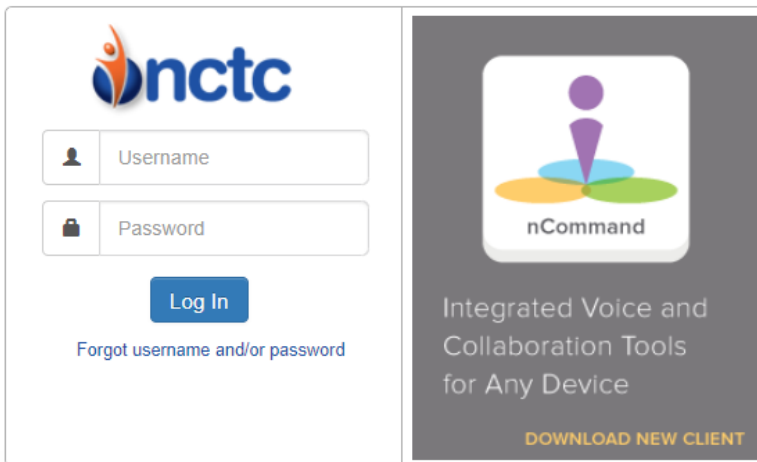

Figure 1 CAP Login Dialog

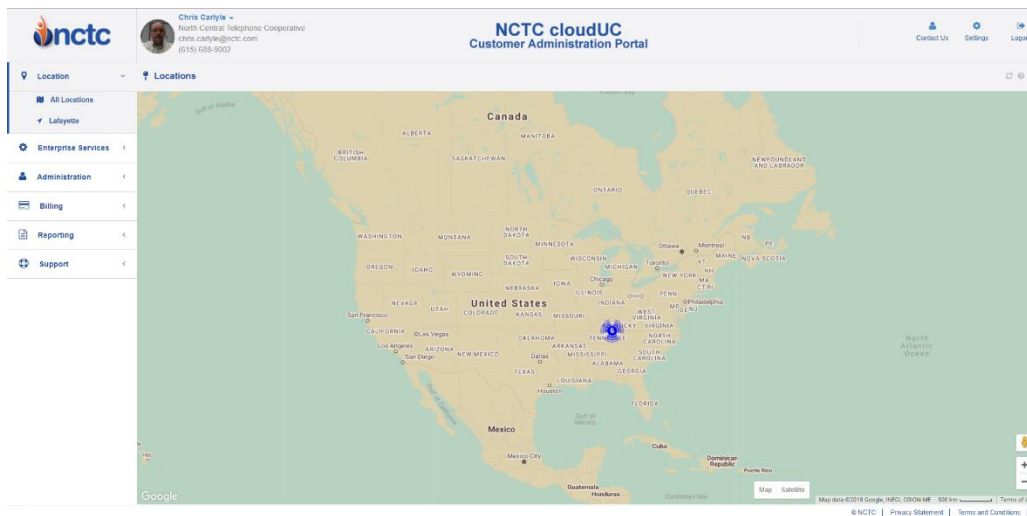

Figure 2 CAP End User Interface

The screenshot displays the NCTC cloudUC Customer Administration Portal. The user is logged in as Chris Carlyle, North Central Telephone Cooperative. The interface shows a sidebar with navigation options like Enterprise Services, Administration, Billing, Reporting, and Support. The main content area is titled 'Lafayette' and contains a table of users and their devices.

Extension	Phone	User Name	Service Plan	Service Status	Device Type	Connected Device	Action
9002	(615) 688-9002	Chris Carlyle	cloudUC Executive	Active	Polycorn VXX 600 PtE MAC 00:04:F2:BC:90:1A	[Icons]	[Icons]
9003	(615) 688-9003	Falisha Adams	cloudUC Executive	Active	Polycorn VXX 500 PtE MAC 00:04:F2:8D:CD:EA	[Icons]	[Icons]
9004	(615) 688-9004	Dewayne Colter	cloudUC Executive	Active	Polycorn VXX 400 PtE MAC 00:04:F2:83:6D:34	[Icons]	[Icons]
9005	(615) 688-9005	Evelyn Gannon	cloudUC Executive	Active	Polycorn VXX 300 PtE MAC 00:04:F2:89:48:89	[Icons]	[Icons]
9006	(615) 688-9006	Nelson White	cloudUC Professional	Active	Polycorn SoundPoint IP 500 PtE MAC 00:04:F2:36:1B:E2	[Icons]	[Icons]
9007	-	NCTC Lobby	cloudUC Basic	Active	Polycorn SoundPoint IP 550 PtE MAC 00:04:F2:3E:80:D6	[Icons]	[Icons]

Showing 1 to 6 of 6 entries. View: 10. First, Previous, Next, Last.

Figure 3 CAP Admin User Interface

## Related NCTC cloudUC Applications

### nCommand

If your account includes mobility features, you should install the nCommand App on your device(s). The nCommand App can be downloaded directly from your device's appstore, Apple or Google Play. Access the appstore and search for "nCommand".

Additionally, nCommand can be installed on Windows PC and Apple Mac. To download software for these devices, please visit <http://ncommandapp.com>.

### Broadsoft Recorder

Recording of various media file such as voicemail greetings, auto attendant greetings and music on hold files can be accomplished using the Broadsoft Recorder app. By using the Broadsoft Recorder app, audio files can be recorded directly from your mobile device and subsequently uploaded via the NCTC cloudUC Customer Administration Portal. To download and install, access the appstore and search for "Broadsoft Recorder".

## Polycom Devices

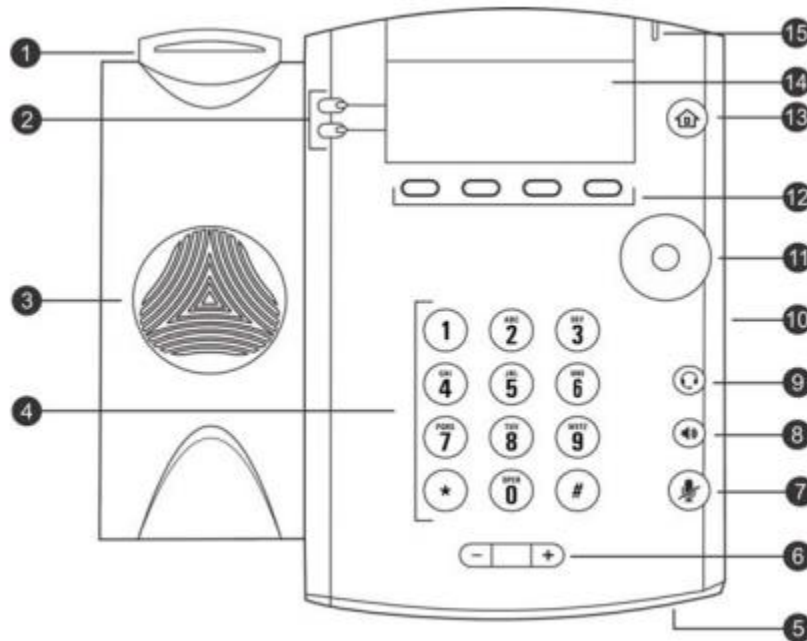

**Figure 1:** VVX 101 and 201 hardware features

### VVX 101 and 201 Hardware Feature Descriptions

<b>Reference Number</b>	<b>Feature</b>	<b>Feature Description</b>
1	Hookswitch	Cradles the handset and end calls.
2	Line keys	Enable you to select a phone line, view calls on a line, or quickly call a favorite contact.
3	Speaker	Provides ringer and speakerphone audio output.
4	Dialpad keys	Enable you to enter numbers, letters, and special characters. You can also use the dialpad keys to select menu items that have index numbers.
5	Microphone	Transmits audio to other phones.
6	Volume keys	Adjust the volume of the handset, headset, speaker, and ringer.
7	Mute key	Mutes local audio during calls and conferences.
8	Speakerphone key	Enables you to place and receive calls using the speakerphone.
9	Headset key	Enables you to place and receive calls through a headset.
10	Security slot (on side)	Enables you to attach a universal security cable lock to your phone so you can secure it to a desktop.
11	Navigation keys / Select key	Scrolls through information or options displayed on the phone's screen. Selects a field of displayed data.

**VVX 101 and 201 Hardware Feature Descriptions (continued)**

<b>Reference Number</b>	<b>Feature</b>	<b>Feature Description</b>
12	Soft keys	Enable you to select context sensitive keys that display along the bottom of the screen.
13	Home key	Displays the Home screen from other screens, and displays the Lines and Calls screen from the Home screen.
14	Screen	Shows a 2.5-inch (6.35 cm) diagonal screen with a backlight that enables you to view menus and data. VVX 101 phones do not have a backlight.
15	Message Waiting Indicator	Flashes red to indicate when you have new messages.

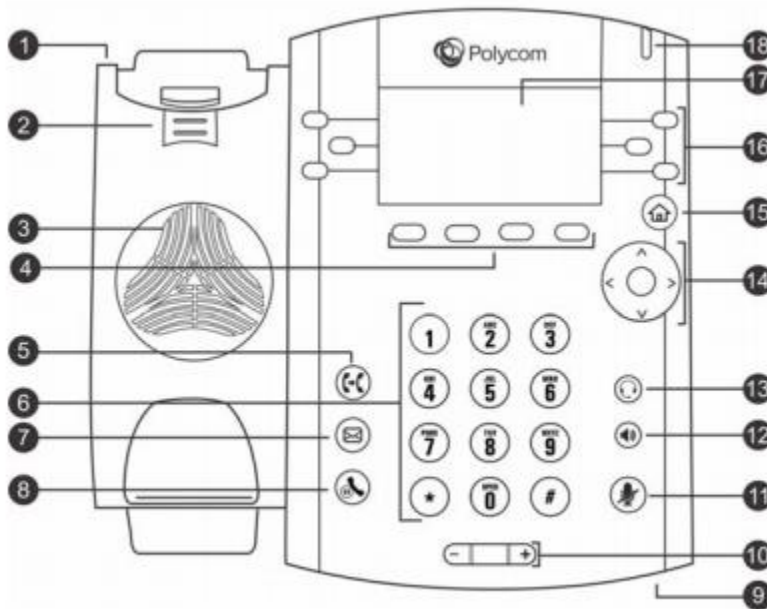

**Figure 2: VVX 300 series hardware features**

**VVX 300 Series Hardware Feature Descriptions**

<b>Reference Number</b>	<b>Feature</b>	<b>Feature Description</b>
1	Security slot (on top)	Enables you to attach a universal security cable lock to your phone so you can secure it to a desktop.

**VVX 300 Series Hardware Feature Descriptions (continued)**

2	Reversible tab	Secures the handset in the cradle when your phone stand is positioned at a high angle. To secure the handset, remove the tab, reverse it so the protrusion points up, and re-insert it. Position the handset so the protrusion on the tab fits into the slot on the handset.
3	Speaker	Provides ringer and speakerphone audio output.
4	Soft keys	Enable you to select context sensitive keys that display along the bottom of the screen.
5	Transfer key	Transfers an active call to a contact.
6	Dialpad keys	Enable you to enter numbers, letters, and special characters. You can also use the dialpad keys to select menu items that have index numbers.
7	Messages key	Enables you to access and manage instant and voice messages.
8	Hold key	Holds an active call or resumes a held call.
9	Microphone	Transmits audio to other phones.
10	Volume keys	Adjust the volume of the handset, headset, speaker, and ringer.
11	Mute key	Mutes local audio during calls and conferences. The key glows red when activated.
12	Speakerphone key	Enables you to place and receive calls using the speakerphone. The key glows green when activated.
13	Headset key	Enables you to place and receive calls through a headset. The key glows green when an analog headset is activated, and blue when a USB or Bluetooth headset is activated.
14	Navigation key/ Select key	Scrolls through information or options displayed on the phone's screen. Selects a field of displayed data.
15	Home key	Displays the Home screen from other screens, and displays the Lines and Calls screen from the Home screen.
16	Line keys	Enable you to select a phone line, view calls on a line, or quickly call a favorite contact.
17	Screen	Shows a 3.2-inch (8.3 cm) diagonal screen with a backlight that enables you to view menus and data.
18	Message Waiting Indicator	Flashes red to indicate when you have new messages.

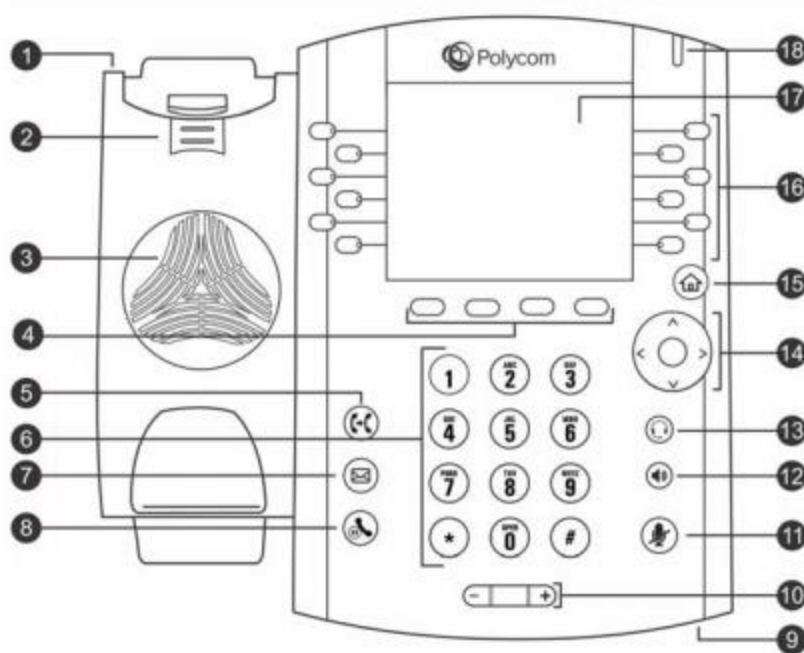

**Figure 3:** VVX 400 series hardware features

**VVX 400 Series Hardware Feature Descriptions**

<b>Reference Number</b>	<b>Feature</b>	<b>Feature Description</b>
1	Security slot (on top)	Enables you to attach a universal security cable lock to your phone so you can secure it to a desktop.
2	Reversible tab	Secures the handset in the cradle when your phone stand is positioned at a high angle. To secure the handset, remove the tab, reverse it so the protrusion points up, and re-insert it. Position the handset so the protrusion on the tab fits into the slot on the handset.
3	Speaker	Provides ringer and speakerphone audio output.
4	Soft keys	Enable you to select context sensitive keys that display along the bottom of the screen.
5	Transfer key	Transfers an active call to a contact.
6	Dialpad keys	Enable you to enter numbers, letters, and special characters. You can also use the dialpad keys to select menu items that have index numbers.
7	Messages key	Enables you to access and manage instant and voice messages.
8	Hold key	Holds an active call or resumes a held call.
9	Microphone	Transmits audio to other phones.
10	Volume keys	Adjust the volume of the handset, headset, speaker, and ringer.

**VVX 400 Series Hardware Feature Descriptions (continued)**

11	Mute key	Mutes local audio during calls and conferences. The key glows red when activated.
12	Speakerphone key	Enables you to place and receive calls using the speakerphone. The key glows green when activated.
13	Headset key	Enables you to place and receive calls through a headset. The key glows green when an analog headset is activated, and blue when a USB or Bluetooth headset is activated.
14	Navigation key/ Select key	Scrolls through information or options displayed on the phone's screen. Selects a field of displayed data.
15	Home key	Displays the Home screen from other screens, and displays the Lines and Calls screens from the Home screen.
16	Line keys	Enable you to select a phone line, view calls on a line, or quickly call a favorite contact.
17	Screen	Shows a 3.5-inch (8.89 cm) diagonal screen with a backlight that enables you to view menus and data.
18	Message Waiting Indicator	Flashes red to indicate when you have new messages.

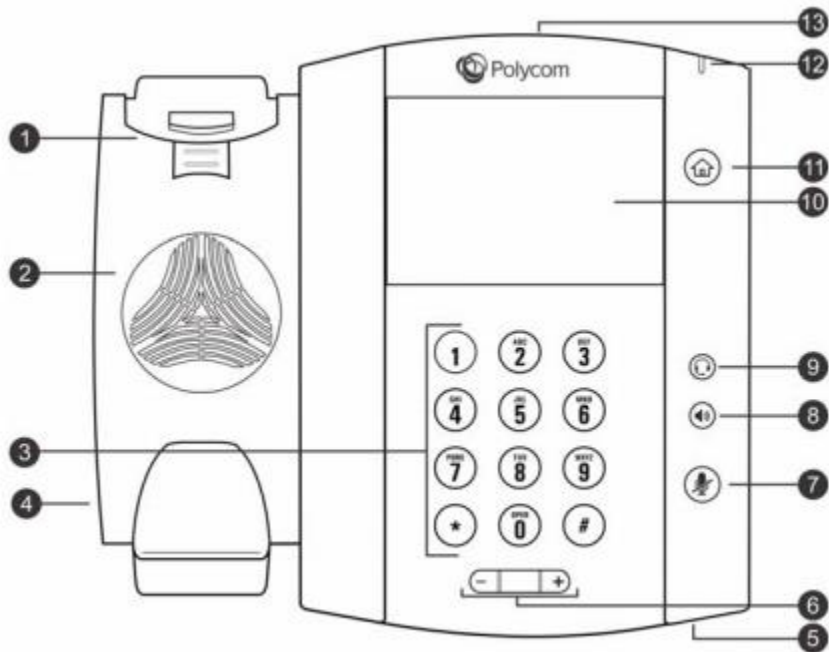
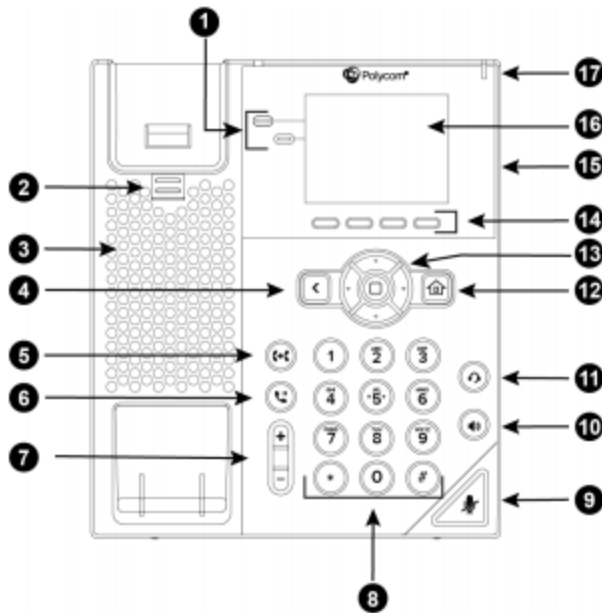

**Figure 4:** VVX 500 series and VVX 600 series hardware features

**VVX 500 Series and 600 Series Hardware Feature Descriptions**

<b>Reference Number</b>	<b>Feature</b>	<b>Feature Description</b>
1	Reversible tab	Secures the handset in the cradle when your phone stand is positioned at a high angle. To secure the handset, remove the tab, reverse it so the protrusion points up, and re-insert it. Position the handset so the protrusion on the tab fits into the slot on the handset.
2	Speaker	Provides ringer and speakerphone audio output.
3	Dialpad keys	Enable you to enter numbers, letters, and special characters. You can also use the dialpad keys to select menu items that have index numbers.
4	Security slot (on side)	Enables you to attach a universal security cable lock to your phone so you can secure it to a desktop.
5	Microphone	Transmits audio to other phones.
6	Volume keys	Adjust the volume of the handset, headset, speaker, and ringer.
7	Mute key	Mutes local audio during calls and conferences. The key glows red when activated.
8	Speakerphone key	Enables you to place and receive calls using the speakerphone. The key glows green when activated.
9	Headset key	Enables you to place and receive calls through a headset. The key glows green when an analog headset is activated, and blue when a USB or Bluetooth headset is activated.
10	Touchscreen	Enables you to select items and navigate menus on the touch-sensitive screen. Tap the screen to select and highlight screen items. To scroll, touch the screen, and swipe your finger up, down, right, or left.
11	Home key	Displays the Home screen from other screens, and displays the Lines and Calls screens from the Home screen.
12	Message Waiting Indicator	Flashes red to indicate when you have new messages.
13	USB port	Enables you to attach a USB flash drive, a USB headset, or a VVX Camera.

**VVX 150 hardware features**



**VVX 150 Hardware Feature Descriptions**

Reference Number	Feature	Feature Description
1	Line keys	Enable you to select a phone line, view calls on a line, or quickly call a favorite contact.
2	Reversible tab	Secures the handset in the cradle when your phone stand is positioned at a high angle. To secure the handset, remove the tab, reverse it so the protrusion points up, and re-insert it. Position the handset so the protrusion on the tab fits into the slot on the handset.
3	Speaker	Provides ringer and speakerphone audio output.
4	Back key	Enables you to return to the previous screen.
5	Transfer key	Transfers an active call to a contact.
6	Hold key	Holds an active call or resumes a held call.
7	Volume keys	Adjust the volume of the handset, headset, speaker, and ringer.
8	Dial pad	Enables you to enter numbers, letters, and special characters. You can also use the dial pad keys to select menu items that have index numbers.
9	Mute key	Mutes local audio during calls and conferences.

Reference Number	Feature	Feature Description
10	Speakerphone key	Enables you to place and receive calls using the speakerphone.
11	Headset key	Enables you to place and receive calls through a headset.
12	Home key	Displays the Home screen from other screens and displays the Lines and Calls screen from the Home screen.
13	Navigation keys / Select key	Scrolls through information or options displayed on the phone's screen. Selects a field of displayed data.
14	Soft keys	Enable you to select context sensitive keys that display along the bottom of the screen.
15	Security slot (on back)	Enables you to attach a universal security cable lock to your phone so you can secure it to a desktop.
16	Screen	Shows a 6.35 cm (2.5-inch) monochrome display that enables you to view menu options and data.
17	Message Waiting Indicator	Flashes red to indicate when you have new messages.

**VVX 250 hardware features**

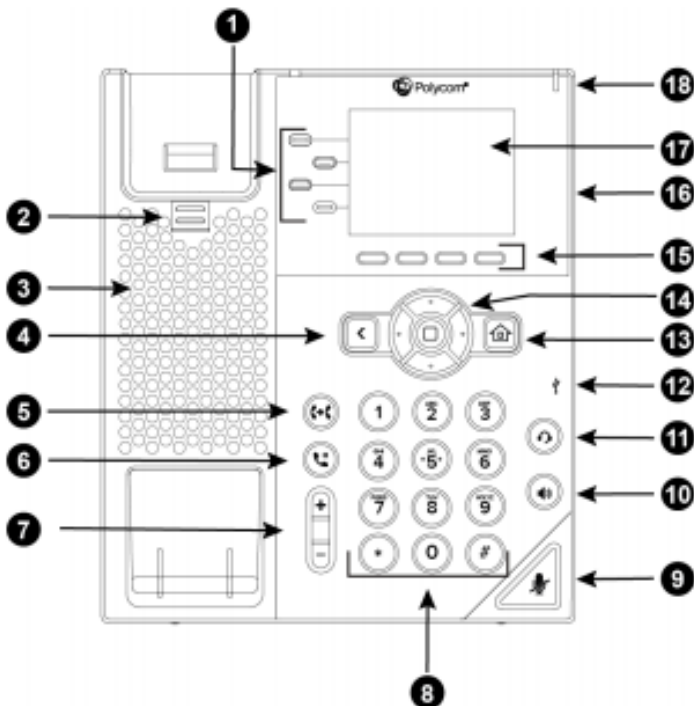

**VVX 250 Hardware Features**

<b>Reference Number</b>	<b>Feature</b>	<b>Feature Description</b>
1	Line keys	Enable you to select a phone line, view calls on a line, or quickly call a favorite contact.
2	Reversible tab	Secures the handset in the cradle when your phone stand is positioned at a high angle. To secure the handset, remove the tab, reverse it so the protrusion points up, and re-insert it. Position the handset so the protrusion on the tab fits into the slot on the handset.
3	Speaker	Provides ringer and speakerphone audio output.
4	Back key	Enables you to return to the previous screen.
5	Transfer key	Transfers an active call to a contact.
6	Hold key	Holds an active call or resumes a held call.
7	Volume keys	Adjust the volume of the handset, headset, speaker, and ringer.
8	Dial pad	Enables you to enter numbers, letters, and special characters. You can also use the dial pad keys to select menu items that have index numbers.
9	Mute key	Mutes local audio during calls and conferences.

Reference Number	Feature	Feature Description
10	Speakerphone key	Enables you to place and receive calls using the speakerphone.
11	Headset key	Enables you to place and receive calls through a headset.
12	USB Port	Enables you to attach a USB flash drive or USB headset.
13	Home key	Displays the Home screen from other screens and displays the Lines and Calls screen from the Home screen.
14	Navigation keys / Select key	Scrolls through information or options displayed on the phone's screen. Selects a field of displayed data.
15	Soft keys	Enable you to select context sensitive keys that display along the bottom of the screen.
16	Security slot (on back)	Enables you to attach a universal security cable lock to your phone so you can secure it to a desktop.
17	Screen	Shows a 7.1 cm (2.8 in) color display that enables you to view menu options and data.
18	Message Waiting Indicator	Flashes red to indicate when you have new messages.

**VVX 350 hardware features**

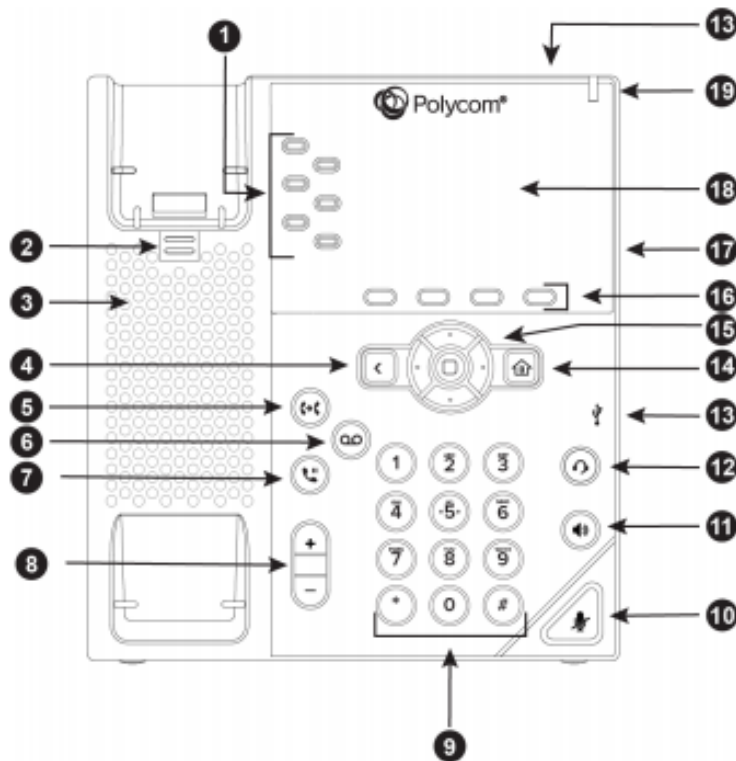

**VVX 350 Hardware Feature Descriptions**

Reference Number	Feature	Feature Description
1	Line keys	Enable you to select a phone line, view calls on a line, or quickly call a favorite contact.
2	Reversible tab	Secures the handset in the cradle when your phone stand is positioned at a high angle. To secure the handset, remove the tab, reverse it so the protrusion points up, and re-insert it. Position the handset so the protrusion on the tab fits into the slot on the handset.
3	Speaker	Provides ringer and speakerphone audio output.
4	Back key	Enables you to return to the previous screen.
5	Transfer key	Transfers an active call to a contact.
6	Messages key	Enables you to access and manage instant and voice messages.
7	Hold key	Holds an active call or resumes a held call.
8	Volume keys	Adjust the volume of the handset, headset, speaker, and ringer.

Reference Number	Feature	Feature Description
9	Dial pad	Enables you to enter numbers, letters, and special characters. You can also use the dial pad keys to select menu items that have index numbers.
10	Mute key	Mutes local audio during calls and conferences.
11	Speakerphone key	Enables you to place and receive calls using the speakerphone.
12	Headset key	Enables you to place and receive calls through a headset.
13	USB Port	Enables you to attach a USB flash drive or USB headset.
14	Home key	Displays the Home screen from other screens and displays the Lines and Calls screen from the Home screen.
15	Navigation keys / Select key	Scrolls through information or options displayed on the phone's screen. Selects a field of displayed data.
16	Soft keys	Enable you to select context sensitive keys that display along the bottom of the screen.
17	Security slot (on back)	Enables you to attach a universal security cable lock to your phone so you can secure it to a desktop.
18	Screen	Shows a 8.89 cm (3.5 in) color screen with a backlight that enables you to view menu options and data.
19	Message Waiting Indicator	Flashes red to indicate when you have new messages.

**VVX 450 hardware features**

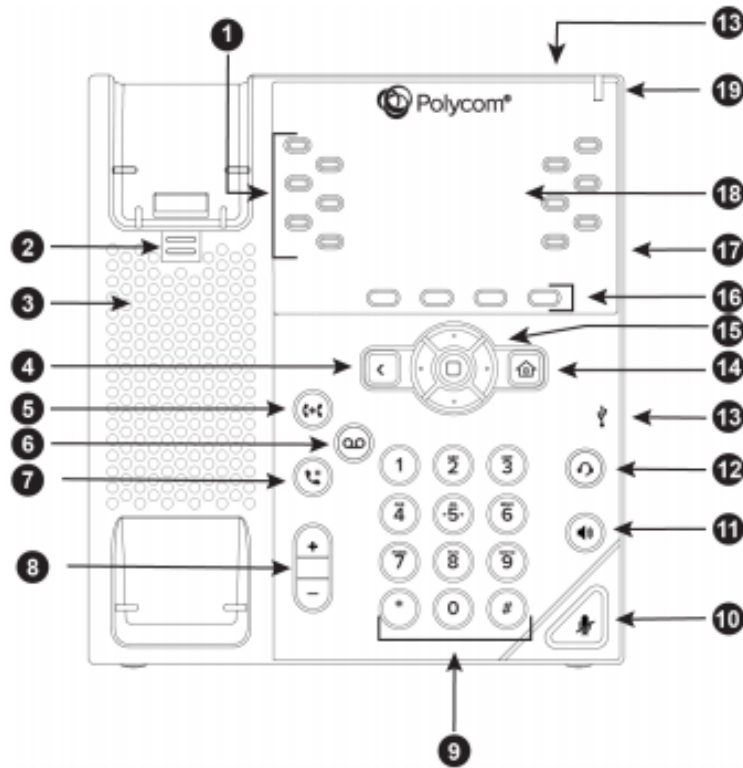

**VVX 450 Hardware Feature Descriptions**

Reference Number	Feature	Feature Description
1	Line keys	Enable you to select a phone line, view calls on a line, or quickly call a favorite contact.
2	Reversible tab	Secures the handset in the cradle when your phone stand is positioned at a high angle. To secure the handset, remove the tab, reverse it so the protrusion points up, and re-insert it. Position the handset so the protrusion on the tab fits into the slot on the handset.
3	Speaker	Provides ringer and speakerphone audio output.
4	Back key	Enables you to return to the previous screen.
5	Transfer key	Transfers an active call to a contact.
6	Messages key	Enables you to access and manage instant and voice messages.
7	Hold key	Holds an active call or resumes a held call.
8	Volume keys	Adjust the volume of the handset, headset, speaker, and ringer.

Reference Number	Feature	Feature Description
9	Dial pad	Enables you to enter numbers, letters, and special characters. You can also use the dial pad keys to select menu items that have index numbers.
10	Mute key	Mutes local audio during calls and conferences.
11	Speakerphone key	Enables you to place and receive calls using the speakerphone.
12	Headset key	Enables you to place and receive calls through a headset.
13	USB Port	Enables you to attach a USB flash drive or USB headset.
14	Home key	Displays the Home screen from other screens and displays the Lines and Calls screen from the Home screen.
15	Navigation keys / Select key	Scrolls through information or options displayed on the phone's screen. Selects a field of displayed data.
16	Soft keys	Enable you to select context sensitive keys that display along the bottom of the screen.
17	Security slot (on back)	Enables you to attach a universal security cable lock to your phone so you can secure it to a desktop.
18	Screen	Shows a 10.9 cm (4.3 in) color display with a backlight that enables you to view menu options and data.
19	Message Waiting Indicator	Flashes red to indicate when you have new messages.

## Using Your Polycom Device

### To Place a Call

Dial the phone number you wish to dial and press the Dial softkey. To place an outbound call, dial the 10 or 11 digit destination number. To dial an internal extension, dial the 4 digit destination extension.

You can switch from handset/speaker mode by lifting the handset and/or using the speaker key.

### To Answer a Call

Simply lift the handset or press the speaker key.

## Mute

To mute a call regardless of whether you are using the handset, a headset or the speakerphone, press the Mute Key. While muted, the remote side of the call will not be able to hear you and the mute key will be illuminated red. To remove the mute, press the Mute Key again.

## Volume

You can adjust the volume of the ringer, speaker, handset or headset using the volume rocker keys.

## To Place a Call on Hold

While active on a call, press the Hold key or the Hold Soft Key to place the current call on hold. To resume a held call, press the Resume Soft Key.

## To Transfer A Call To Another Extension

While active on a call, press the Transfer Key or the Transfer Soft Key; the caller is automatically put on hold.

### To Perform a Consult Transfer:

Dial the Extension you wish to transfer to and press the Send Soft Key. Once they answer, announce the call. When you are ready to complete the transfer, press the Transfer Key again or press the More SoftKey then press the Transfer Soft Key.

### To Perform a Blind Transfer:

Press the Blind Soft Key then enter the extension you wish to transfer to, then press the Send Soft Key.

### To Transfer A Call to Another Extension Using BLF Key

The procedure to transfer using all BLF key is the same as above however instead of manually entering an extension number, press the Lines Soft Key to show your Line keys. Press the BLF key for the extension you wish to transfer to.

### To Transfer A Call Directly to A Mailbox

While active on a call, press the Transfer Key or the Transfer Soft Key; the caller is automatically put on hold. Enter \*55 followed by the mailbox number where you wish to transfer the call, then hang-up. For example to transfer to mailbox 1000, you would dial \*55, 1000, then hang up.

## To Park a Call

Calls can be parked rather than transferred where more convenient. A call that is parked, is placed into a virtual park zone associated with a particular extension. Calls that are parked will recall to the extension that parked the call if not retrieved. A parked call can be retrieved from any extension using the Retrieve feature code.

### VVX 100/200/300/400/500/600

To Park a call, while active on a call, press the Park Soft Key. You will be prompted to enter an extension where you would like to park the call. Enter a valid extension number followed by the # key or to park to your own extension, press #.

If your phone does not have a Park Soft Key, put the caller on hold. Place a second call to \*68. You will be prompted to enter the extension where you would like to park the call. Enter a valid extension number followed by the # key or to park to your own extension, press #.

#### VVX 150/250/350/450

To Park a call, while active on a call, press the hold key, then dial \*68 followed by the extension where you would like the call parked. For example to park the call to extension 1000, press Hold, then dial \*68 followed by 1000.

#### To Retrieve a Parked Call

To retrieve a parked call, from any phone dial the Retrieve feature code, \*88 or press the Retrieve key if one is programmed. When prompted, enter the extension that the call was parked to followed by #. To retrieve a call parked to your extension, press #.

#### To Setup your Voice Mail

The first thing that you should do is to setup your voicemail. This includes defining your passcode and recording your name.

From your phone, press the Messaging Key or dial \*62, you will be first prompted to change your passcode. Follow the prompts to complete.

Next you will be prompted to record your name; follow the prompts to complete recording your name.

#### To Record Voice Mail Greetings

To record your Voice Mail Greeting, from your phone, press the Message Key or dial \*62. When prompted, enter 1 to access your voice mailbox. Select 2 to record/change your busy greeting, 3 to record/change your no answer greeting, and 4 to record/change your extended absence greeting.

Additionally, you can record greetings using the Broadsoft Recorder app on your mobile device and upload them via the Customer Administration Portal in the messaging configuration.

#### To Listen To Voice Mail Messages

When you have a new Voice Mail Message, the Message Waiting Indicator will flash red AND the icon in the display for your extension will display an envelope.

Press the Message key or dial \*62 to log into voicemail, then press 1 to access your Voice Mail

To check your Voice Mail Messages remotely, dial your DID#, once Voice Mail answers, press \* and follow the prompts.

#### To Transfer A Message to Another User

After listening to a message, press 9 for more options, then press 2 to forward the message. Follow the prompts to record an introduction and define the desired recipient(s).

#### Call Forwarding

You can forward your calls in various ways including, always, busy and no answer. Calls can be forwarded to another extension or to an outside telephone number. Call forwarding features can be enabled via telephone buttons, feature code or the Customer Admin Portal.

### Call Forwarding via Telephone

Press the Home Key to display the applications screen. Using the scroll keys, highlight and select Forward. Use the scroll keys to select Always, No Answer or Busy condition then press the Select Soft Key. In the Contact field, enter the extension or 10 digit phone number where you would like to forward to. Press the Enable Soft Key to Enable/Disable forwarding for this condition. When your phone is forwarded, the icon next to your extension in the display will indicate such.

## Call Forwarding via Feature Code

From your phone, dial the appropriate feature code to administer call forwarding:

- \*72 Activate Call Forward Always
- \*73 Deactivate Call Forward Always
- \*90 Activate Call Forward Busy
- \*91 Deactivate Call Forward Busy
- \*92 Activate Call Forward No Answer
- \*93 Deactivate Call Forward No Answer

## Call Forwarding via Customer Admin Portal

Login into the CAP by visiting <http://clouduc.nctc.com>

Login using your account username and password. From the My Extension menu, click the Edit link for your extension.

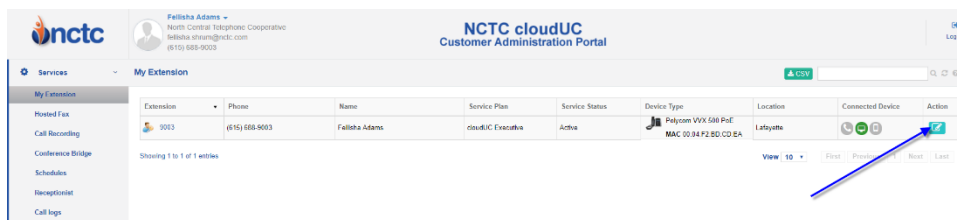

Select the Incoming Calls tab to view its settings.

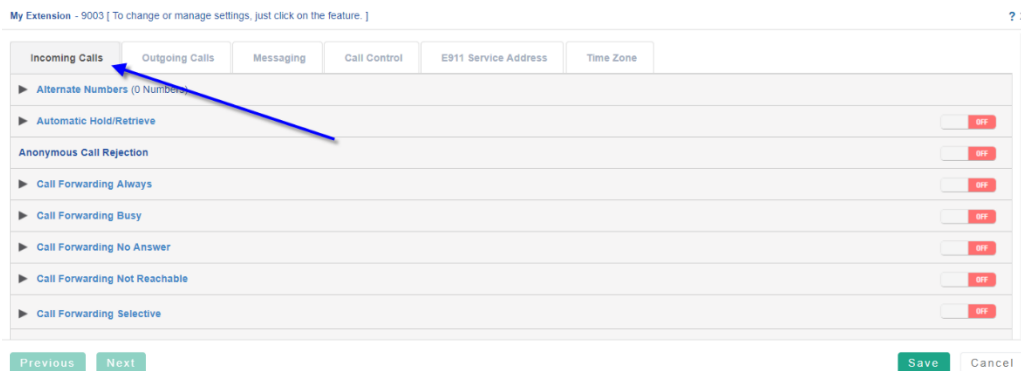

From the Incoming Calls area, select the Call Forwarding type you wish to administer. This includes Call Forwarding Always, Call Forwarding Busy and Call Forwarding Busy. Once the Call Forward Type is expanded, enter a Destination Number/Extension and enable to Call Forwarding type. Click the Save button to save your changes.

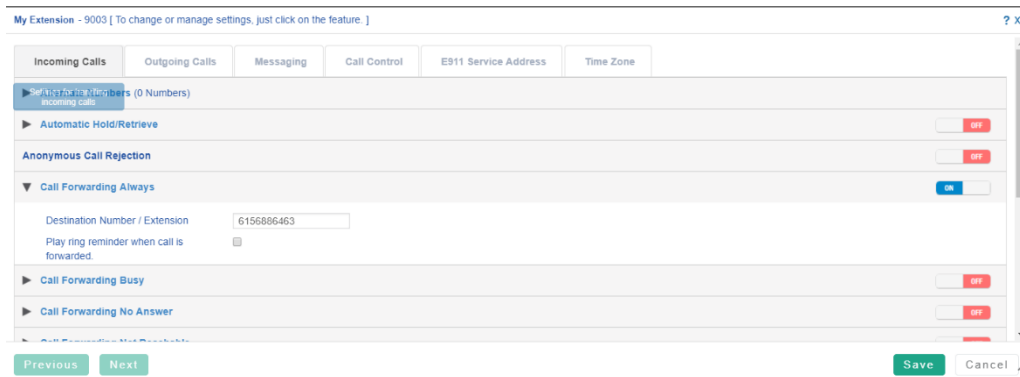

Figure 4 Call Forwarding Conditions

## Do Not Disturb

Do Not Disturb (DND) can be used when you do not desire to take any phone calls. When in DND, all calls to your extension will go to your voice mail automatically. DND can be enabled/disabled several ways.

To enable/disable DND, press the DND Soft Key. When DND is enabled, the icon in the display for your extension will display such.

To enable/disable DND from the Applications screen on Polycom phones, press the Home key to access Applications, then select DND.

To enable/disable DND via feature code, from your phone dial \*78 to enable, and \*79 do disable.

DND can also be enabled/disabled via the Customer Administration Portal in the My Extension widget>>Incoming Calls area.

Note that hunt group calls will not be redirected to voicemail when a member is in DND. If a member is in DND and a hunt group call is routed to that member, they will be considered unavailable and normal hunt group processing will continue.

## Call History

Your phone keeps record of placed, received and missed calls. To access your call history, press the Callers Soft Key. By default, Placed calls are displayed. To view another type, press the Type Soft Key, using the scroll keys select the history you wish to view.

Once the history type you wish to view is displayed, you can scroll the list using the Scroll Keys to highlight a specific entry. For each entry you can view detailed info using the Info Soft Key, Sort using the Sort Soft Key and Dial the number using the Dial Soft Key.

Additionally, call history can be viewed via the Customer Administration Portal in the Call Logs widget. Note that call logs in the Customer Administration Portal are not instantaneous and can take several minutes to appear.

## Redial

To redial a recent call, press the New Call Soft Key. A list of recent calls will be displayed. To redial a number in the list, select it using the Scroll Keys then press the Send Soft Key.

## Conference Calling

Your phone is capable of a multi-party conference call without using a conference bridge. While on a conference call, multiple parties, both internal and external can participate in the call.

To start a conference call, while on a current call, press the Transfer/Conference button or the More soft key then Confrnc soft key.

Dial the second party for the call. This can be an internal extension or an external phone number.

Once the second party answers, press the Transfer/Conference button or the More soft key then Confrnc soft key again. This will join you and the other two callers into the conference.

Repeat this process to add additional parties. When you are done with the call, simply hang up. Note that when you leave the call, all other participants will be dropped from the call.

## Feature Codes

Some features can be accessed via feature code as well as via soft key and or fixed button keys.

*72	Call Forwarding Always Activation
*73	Call Forwarding Always Deactivation
*90	Call Forward Busy Activation
*91	Call Forward Busy Deactivation
*92	Call Forward No Answer Activation
*93	Call Forward No Answer Deactivation
*44	Call Recording (if enabled)
*67	Calling Line ID Delivery Blocking per Call
*65	Calling Line ID Delivery per Call
*68	Call Park
*88	Call Park Retrieve
*98	Call Pickup
*11	Call Retrieve (Call Pull)
*69	Call Return
*70	Cancel Call Waiting
*99	Clear MWI
*55	Direct Voicemail Transfer

*78	Do Not Disturb Activation
*79	Do Not Disturb Deactivation
*62	Voice Portal Access
*66	Last Number Redial

*\*Note that not all features are available on all seat subscriptions*